

GENERAL INSTRUCTIONS

Refer to the recommended clutch removal procedures in the manufacturer's service manual for the vehicle being repaired. The following procedures provide general instructions for clutch removal. Prior to removal make sure that the vehicle is stable and cannot move. Use wheel chocks and jack stands as necessary to assure a safe work area.

1. Disconnect the transmission electrical wiring and transmission air lines.
2. Disconnect the speedometer cable and/or wiring.
3. Disconnect the clutch release linkage system from the transmission.
4. If a hydraulic system is used to operate the clutch, disconnect the pushrod and the spring from the release lever. Remove the hydraulic cylinder from the support bracket on the transmission. Support the cylinder with wire attached to the frame.
5. Put marks on the yoke or the flange of the driveshaft and the output shaft of the transmission. These marks are necessary to assure the driveshaft is correctly reinstalled.
6. Remove the driveshaft. Support the rear of the engine if necessary (nodal mounting systems).
7. Support the transmission using a transmission jack.
8. Rotate the clutch release yoke so that it will clear the clutch release bearing.
9. Remove the fasteners that attach the transmission to the frame cross-member.



CAUTION

Keep the transmission in line with the engine during removal. Do not allow the weight of the transmission to hang on the input shaft. Doing so could bend the clutch disc hub or result in internal transmission damage.

10. Remove the capscrews and washers that attach the clutch housing to the engine. Pull the transmission straight back from the engine until it has cleared the Pressure Plate and Cover Assembly (PPCA) (Fig. 7-1). Remove the transmission from the vehicle.
11. If a clutch brake is used, remove the assembly from the input shaft. Inspect the transmission input shaft bearing retainer surface for excessive wear and/or damage. Repair as necessary.
12. If the clutch is to be reinstalled, install a shipping clip under the head of each of the 4 allen-head capscrews that attach the drive straps to the pressure plate (Fig. 7-2). The clips will keep the pressure plate in a partially retracted position and make pressure plate installation easier.

GENERAL INSTRUCTIONS

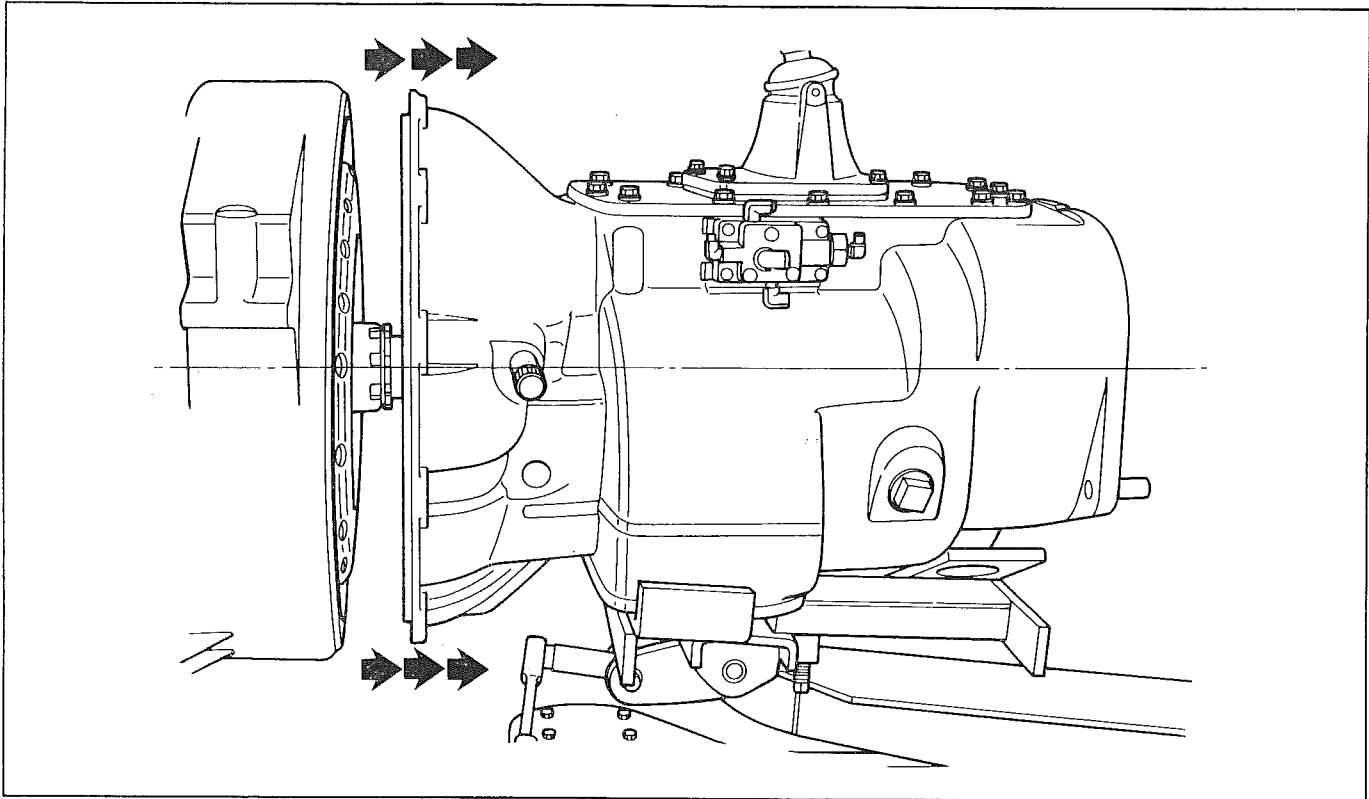

Figure 7-1. Pulling Transmission Away From Engine

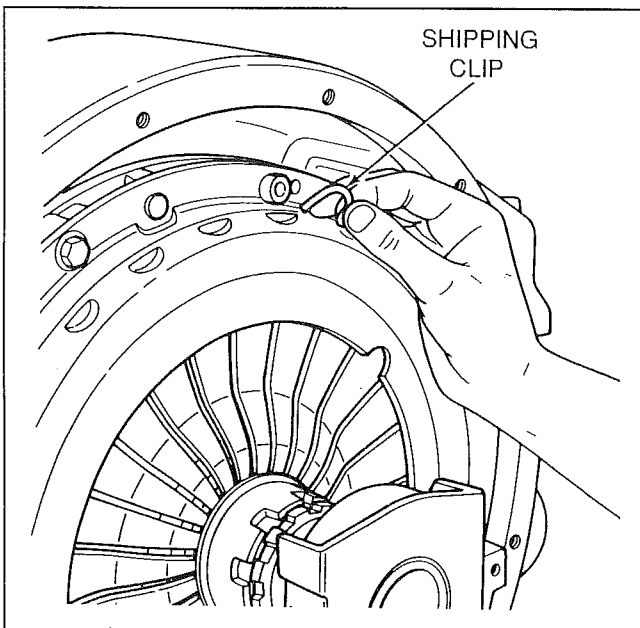

Figure 7-2. Installing Shipping Clips

13. Insert the clutch disc alignment tool through the release bearing and clutch disc and into the pilot bearing (Fig. 7-3).
14. Loosen, but do not remove the capscrews attaching the PPCA to the flywheel. The capscrews should be loosened in an alternating pattern. This will allow the diaphragm spring to relax in a uniform manner.

GENERAL INSTRUCTIONS

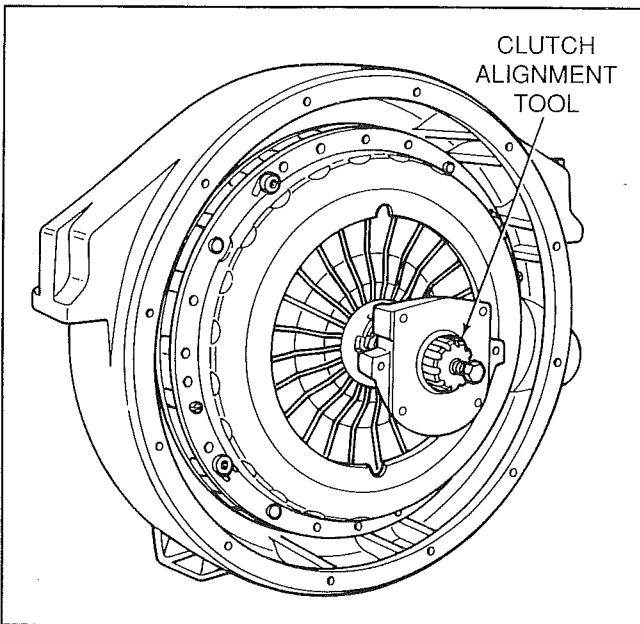

Figure 7-3. Clutch Alignment Tool
Installed for Clutch Removal

! CAUTION

Do not loosen or remove the four allen-head capscrews attaching the drive straps to the clutch pressure plate. Removal and reinstallation of these capscrews can cause the clutch to be out of balance and/or cause the clutch to drag.

15. Remove two PPCA attaching capscrews, 180 degrees opposed to each other.
16. Install two alignment pins in the capscrew holes (Fig. 7-4).
17. Remove the remaining PPCA attaching capscrews.
18. Remove the PPCA by sliding it straight back and off the two alignment pins.

! CAUTION

Do not drop or handle the PPCA roughly. Doing so can cause minor bends or kinks in the four drive strap assemblies. Any bends or kinks can reduce or eliminate the ability of the pressure plate to retract into the clutch cover and cause incomplete clutch release (clutch drag).

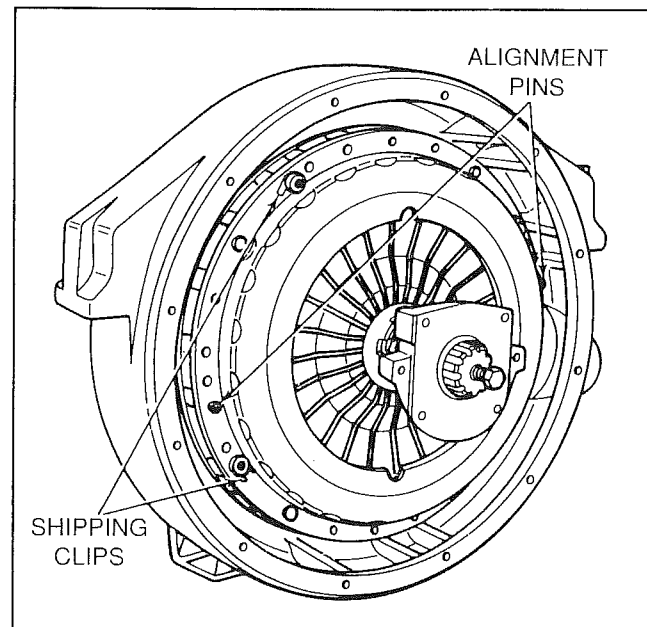

Figure 7-4. Alignment Pins Installed
for PPCA Removal

19. Remove the clutch disc and clutch alignment tool
20. If necessary, remove the pilot bearing using a bearing puller and discard the bearing (Fig 7-5).

GENERAL INSTRUCTIONS

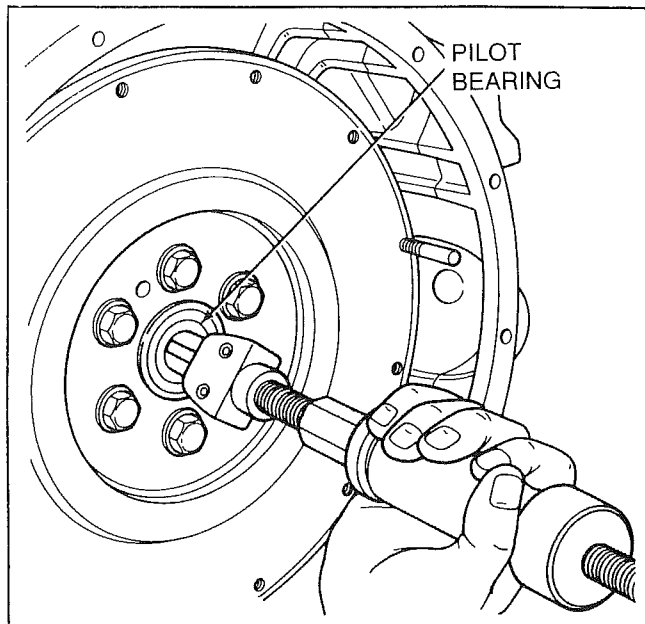

Figure 7-5. Removing the Pilot Bearing